

GSTCK

Quick Installation Guide

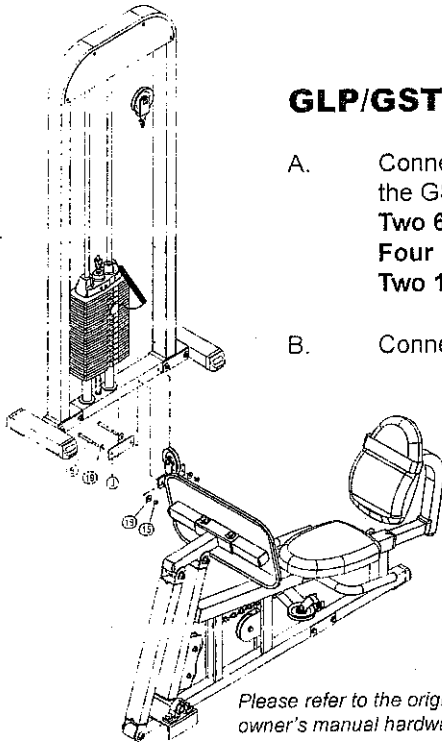

GLP/GSTCK

- A. Connect Linkage Frame (A) and Flat Plate (J) to the GSTCK using:
 - Two 6 (M10x110 hex head bolt)
 - Four 19 (M10 washer)
 - Two 15 (M10 nylon lock nut)
- B. Connect Cable (37) to the GSTACK as shown.

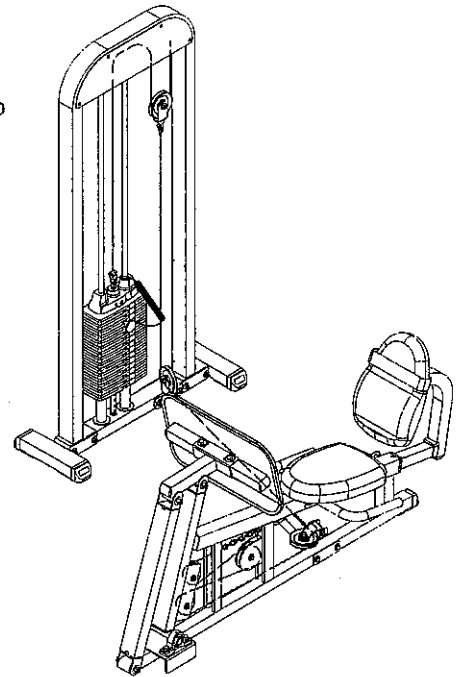

Please refer to the original owner's manual hardware.

Body-solid

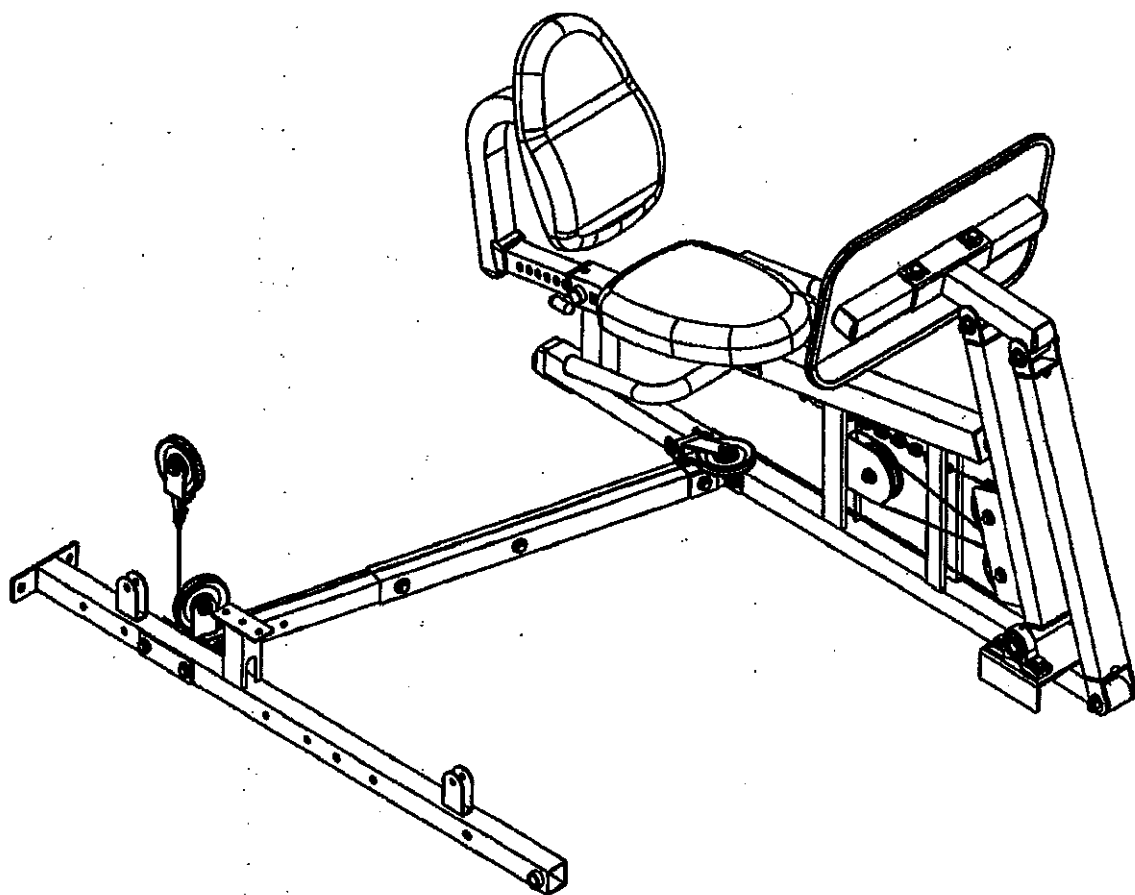

Assembly & Instructions

GLP.3 OWNER'S MANUAL

GLP HARDWARE ILLUSTRATION

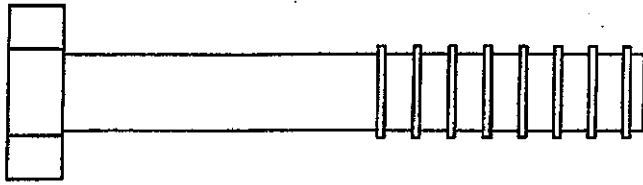

(A1) HEX BOLT M12X80 PARTIAL THREAD QTY.2

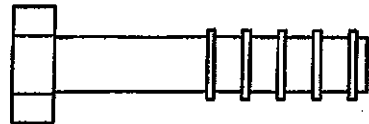

(A2) HEX BOLT M10X45 PARTIAL THREAD QTY.3

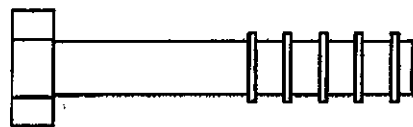

(A3) HEX BOLT M10X50 PARTIAL THREAD QTY.2

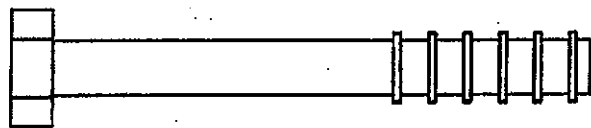

(A4) HEX BOLT M10X75 PARTIAL THREAD QTY.5

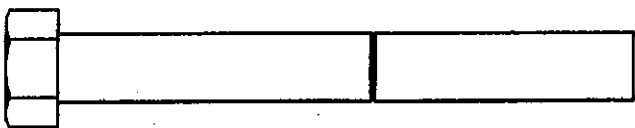

(A5) HEX BOLT M10X80 PARTIAL THREAD QTY.2

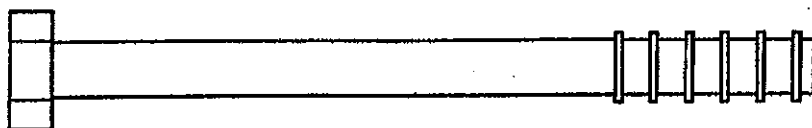

(A7) HEX BOLT M10X110 PARTIAL THREAD QTY.2



GLP HARDWARE ILLUSTRATION

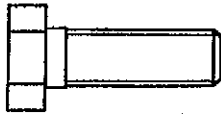

(A8) HEX BOLT 5/16"x1" PARTIAL THREAD QTY. 4



(A9) HEX BOLT 5/16" x3 1/4" PARTIAL THREAD QTY. 2

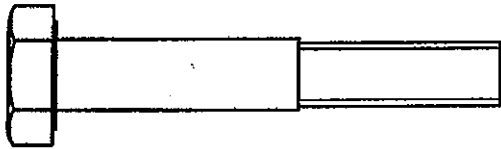

(A10) HEX BOLT M10x65 PARTIAL THREAD QTY. 2



M10

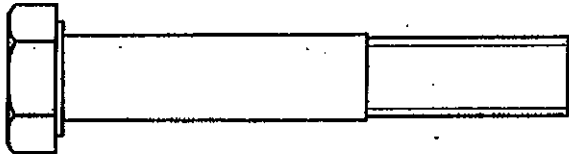

(A11) HEX BOLT M12x75 PARTIAL THREAD QTY. 1



M12

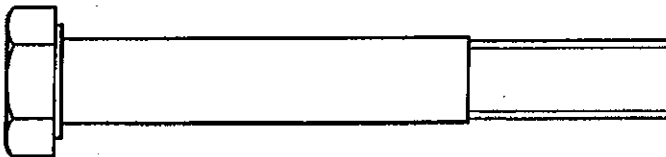

(A12) HEX BOLT M12x90 PARTIAL THREAD QTY. 1



M12

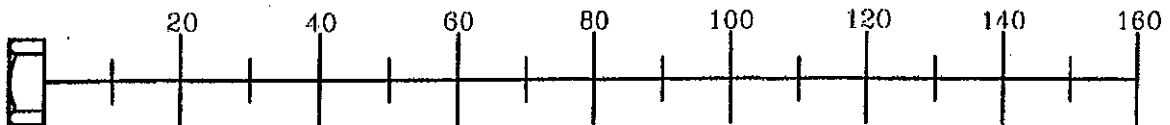

GLP HARDWARE ILLUSTRATION



(B1) NYLON LOCK NUT M12 QTY. 4

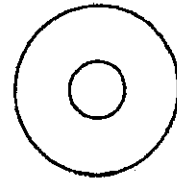

(C4) 5/16" (I.D.) FLAT WASHER Ø24 QTY. 6



(B2) NYLON LOCK NUT M10 QTY. 16

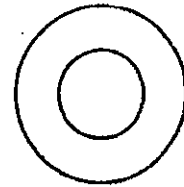

(C5) M12 (I.D.) FLAT WASHER Ø25 QTY. 4

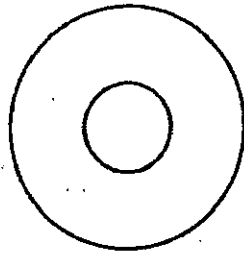

(C1) M12 (I.D.) FLAT WASHER Ø34 QTY. 6

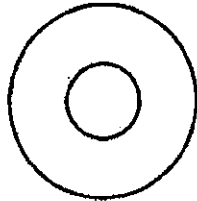

(C2) M10 (I.D.) FLAT WASHER Ø27 QTY. 32



(C3) M5/16" SPRING WASHER QTY. 6

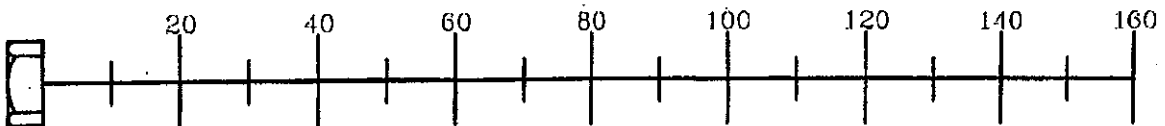

GLP HARDWARE ILLUSTRATION

- D1. Ø8 Spring Snap Link (8810-001) _____ [1PCS]
- D2. □50x2.5t Round End Cap (9211-088) _____ [4PCS]
- D3. 2"x2" Foot Cap (9211-025) _____ [1PCS]
- D4. 45x60 Nylon Bushing (9211-047) _____ [1PCS]
- D6. 45x50 Rubber Dount (9212-039) _____ [1PCS]
- D7. Ø1" Round End Cap (9260-021) _____ [2PCS]
- D8. 3835mm Steel Cable _____ [1PCS]
- D9. Ø4 1/4" Pulley (9213-002C) _____ [5PCS]

D1



D2



D3

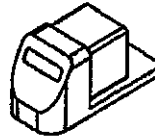

D4

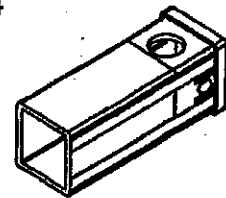

D6



D7



D9



D8



GLP PARTS ILLUSTRATION SHEET

A3 [1PCS]

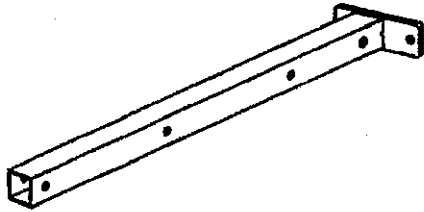

B [1PCS]

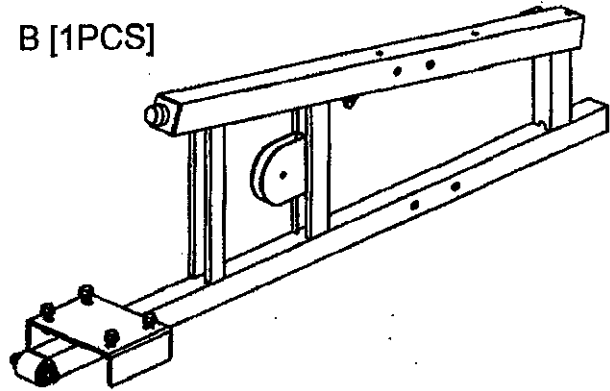

C [1PCS]

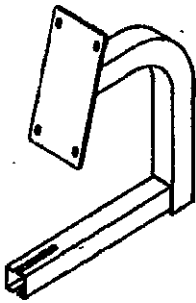

D [1PCS]

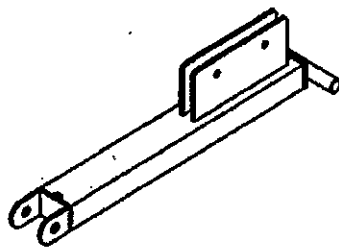

E [1PCS]

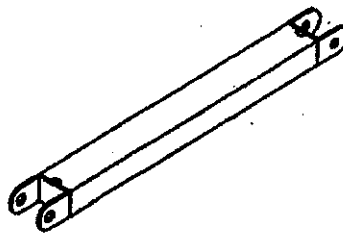

F [1PCS]

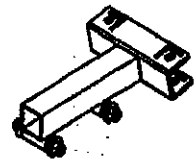

G [1PCS]

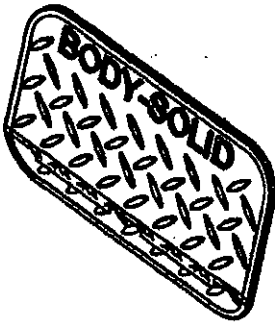

H [2PCS]

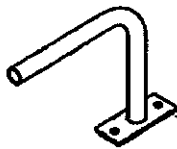

J [2PCS]
8312-090



K [2PCS]
8510-005



L [1PCS]
9121-045

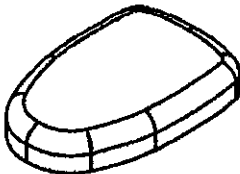

M [1PCS]
9111-049

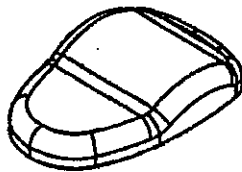

N1 [1PCS]

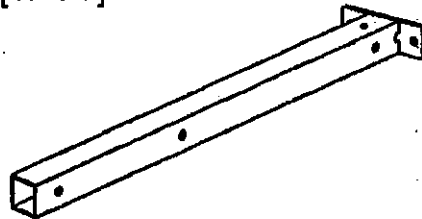

O1 [1PCS]



P [1PCS]



Q [1PCS]



IF Mode A: □50X50 Steel Tube
 uses A4 Bolt for G2B,G3S,G6B,G5S—(2PCS each)
 IF Mode B: □50X75 Steel Tube
 uses A7 Bolt for G4I,G10B—(2PCS each)

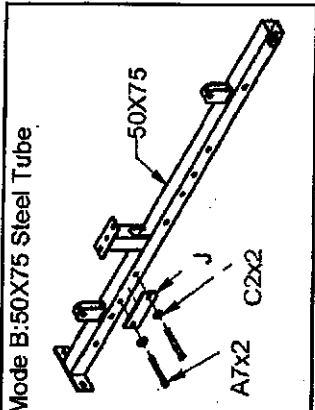

Please adjust the length between A3 to N1
 approximately to 1112mm
 Suitable TO model:G6B,G6S,G10B

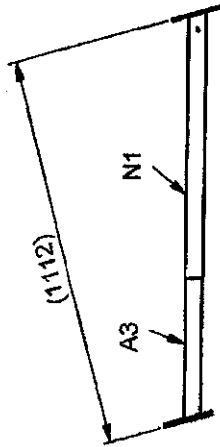

Please adjust the length between A3 to N1
 approximately to 862mm
 Suitable TO model:G2B,G3S,G4I

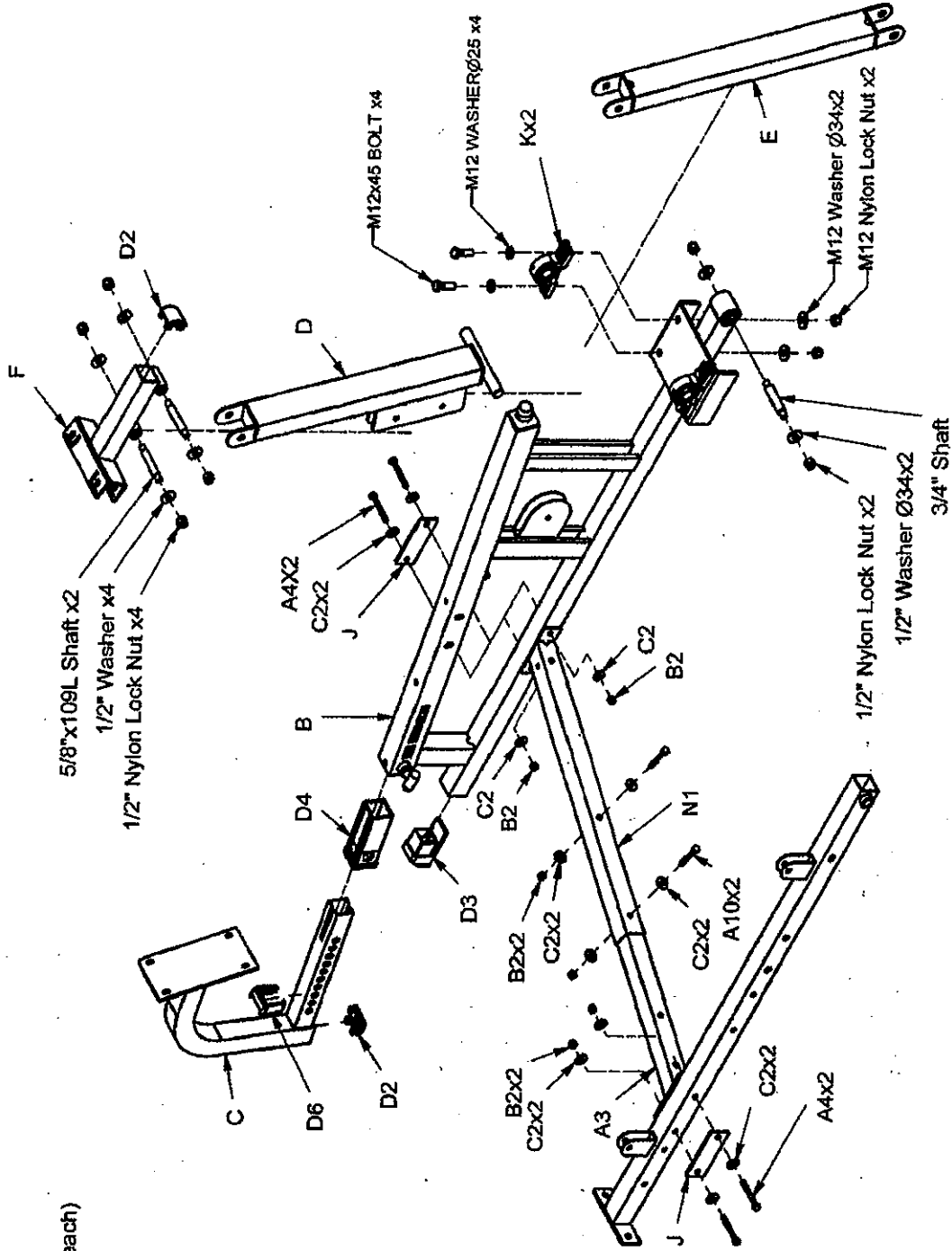
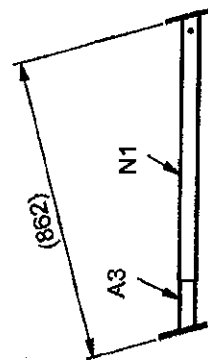

LP ON LEFT

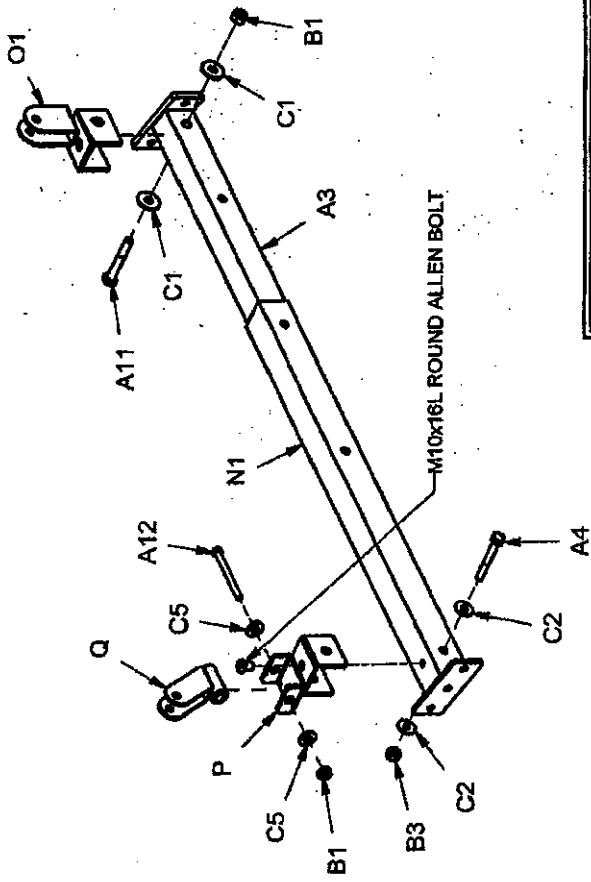

LP ON RIGHT

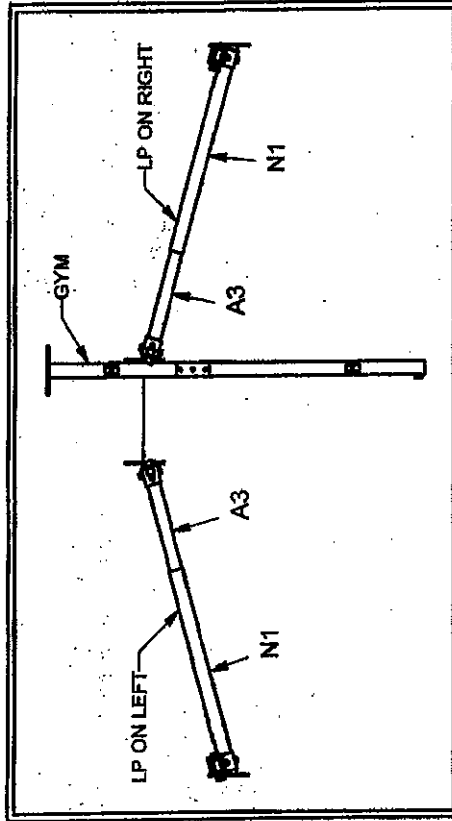
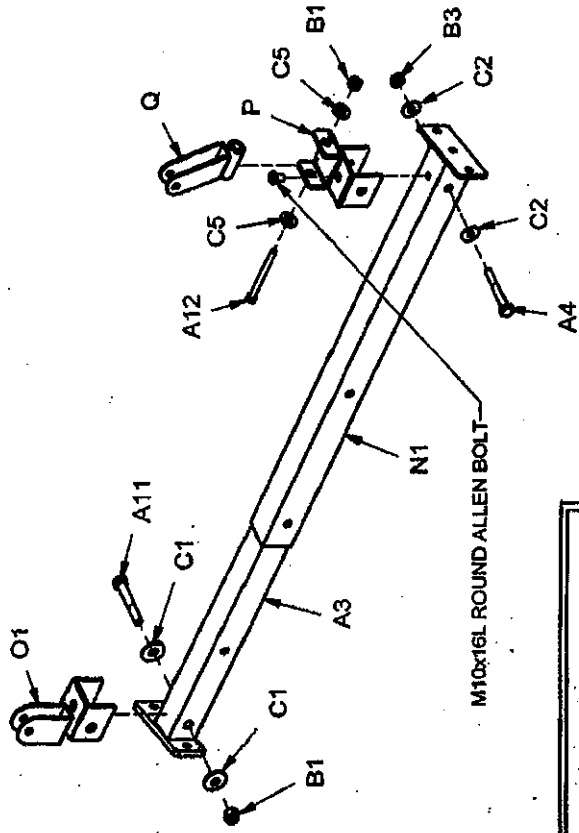

GLP.3-062008

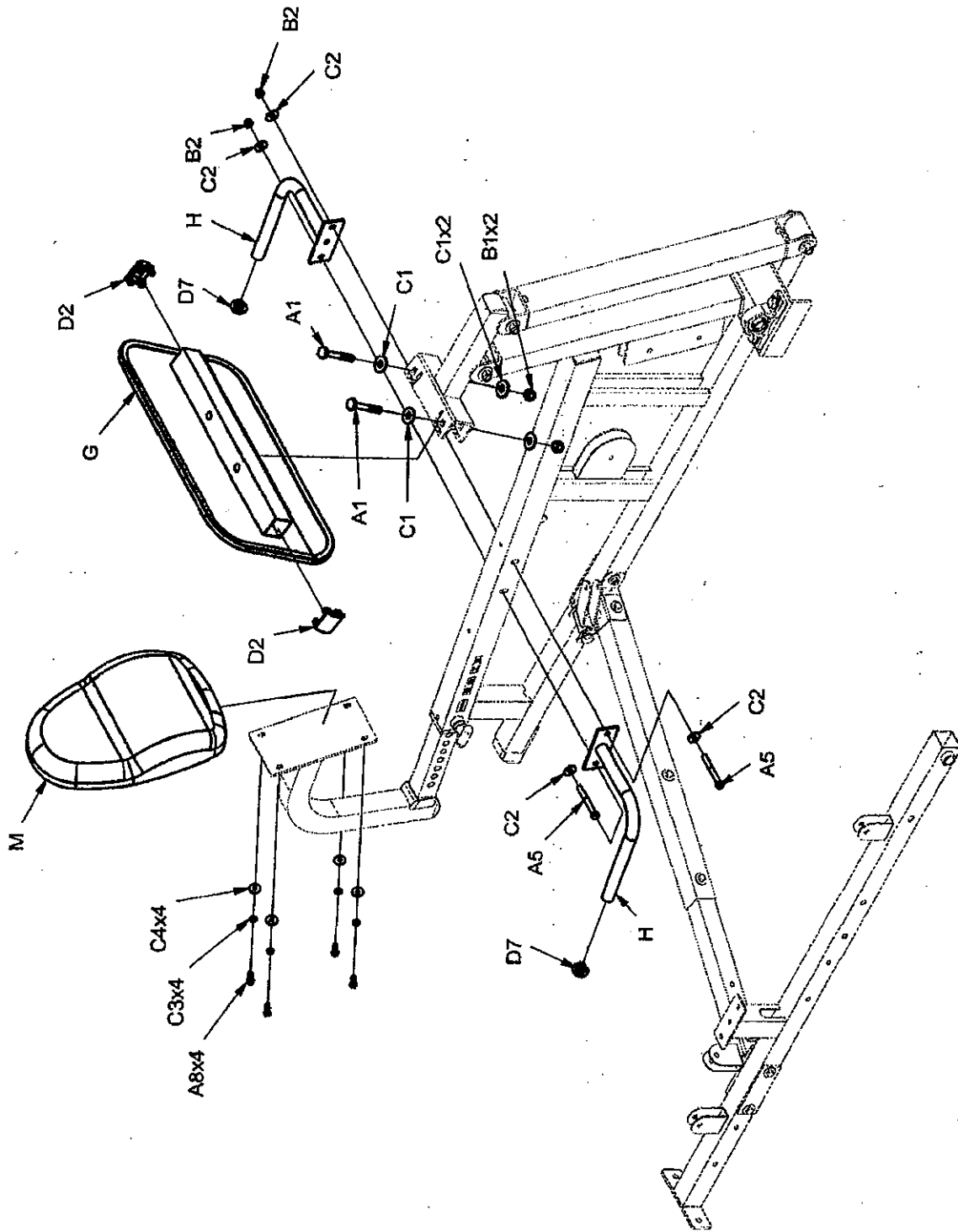

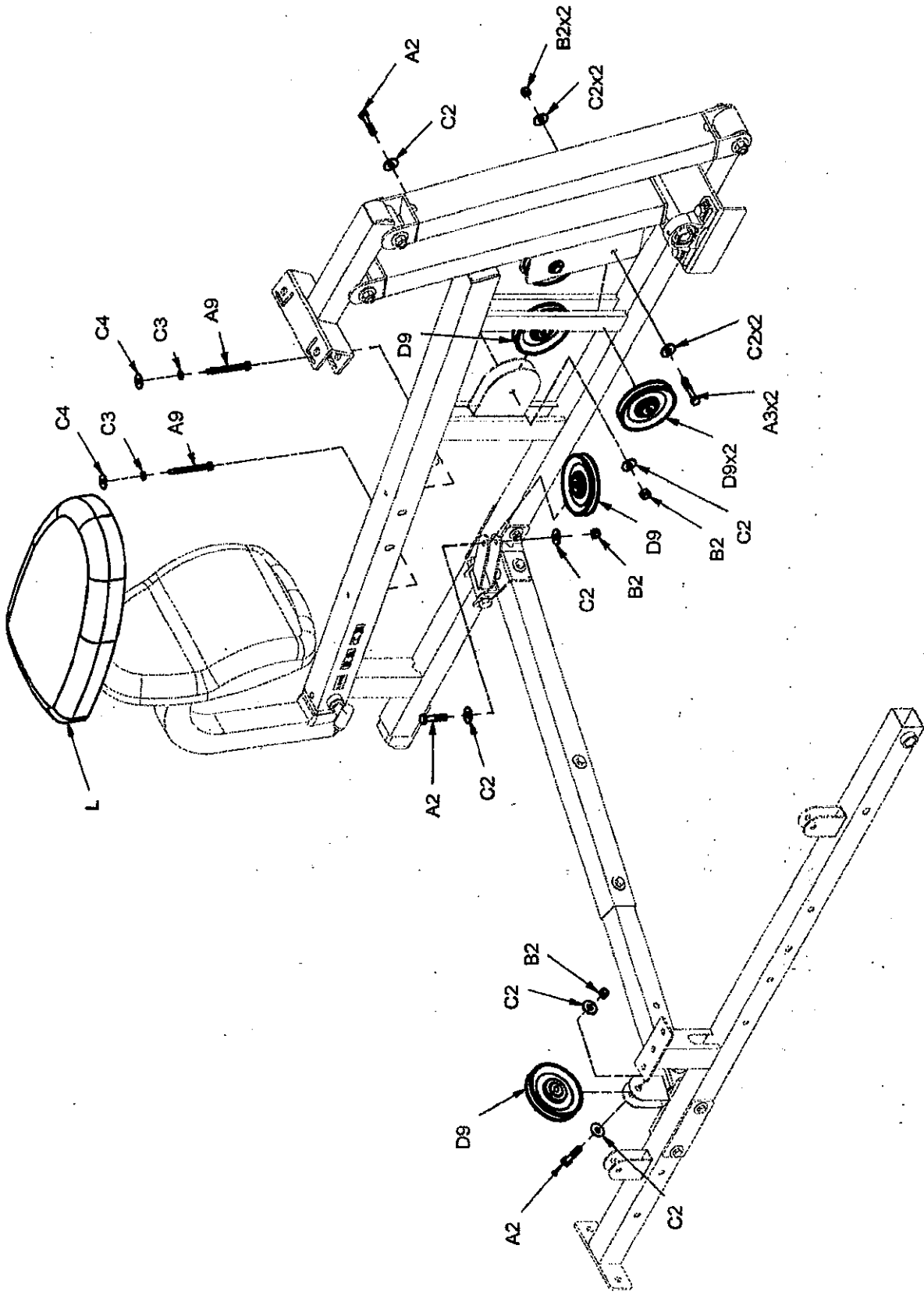

3LP.3-062008



Suitable to model:G2B,G3S,G4I

Suitable to model:G6B,G5S,G10B

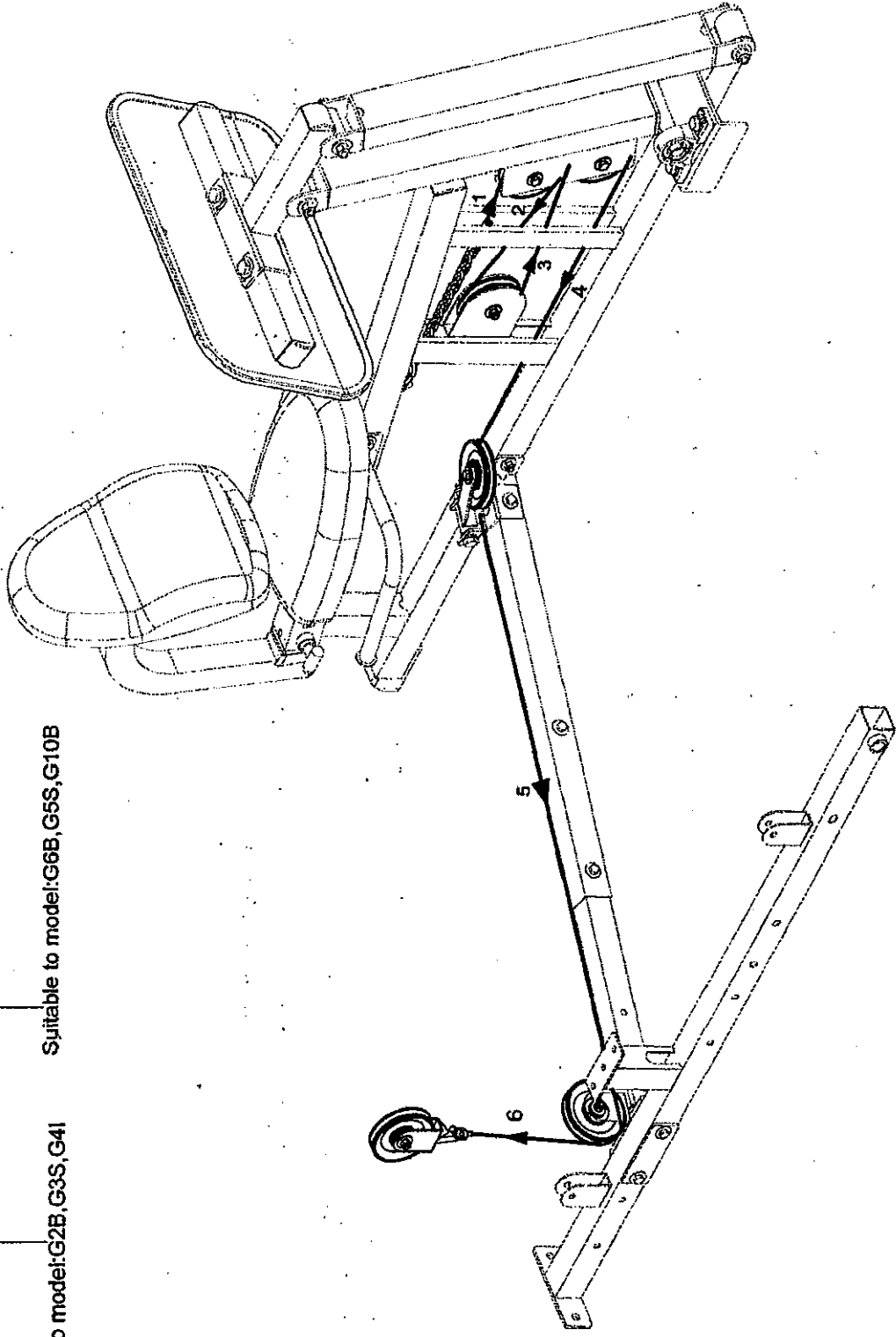

Body-Solid[®]
Built for Life

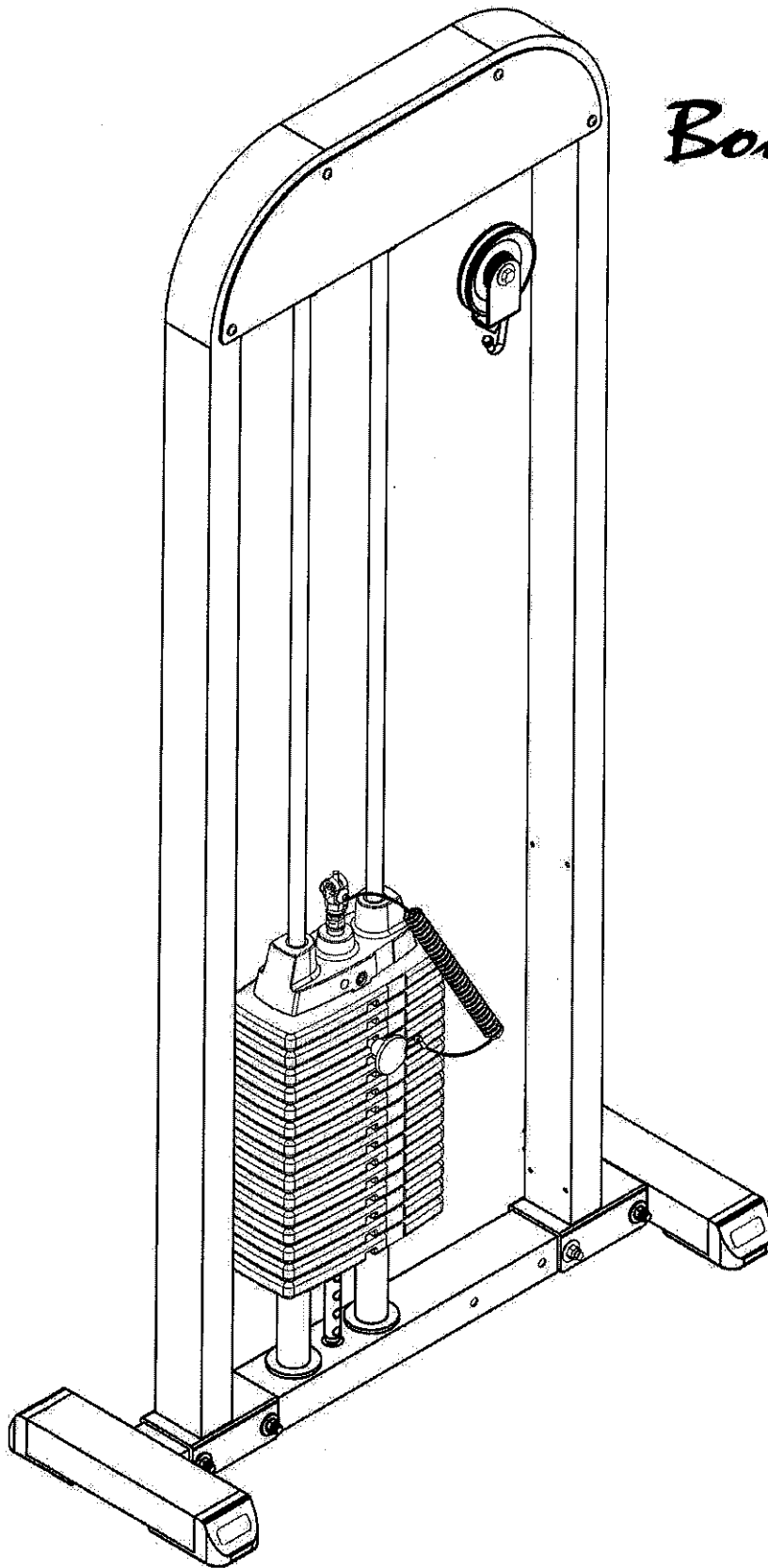

**G-STACK
ASSEMBLY INSTRUCTIONS**

STEP

1

Be careful to assemble all components in the sequence they are presented.

- A. Attach Lower Main Frame (A) to the Upper Main Frame (B) as shown using:
Four 27 (3/8" x 4" hex head bolt)*
Eight 31 (3/8" washer)
Four 37 (3/8" nylon lock nut)
- B. Slide four Foot Caps (1) into Lower Base Frame (A).

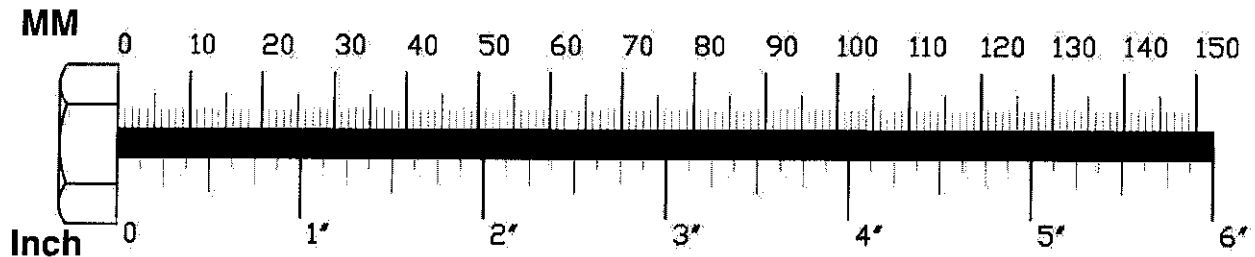

STEP
1

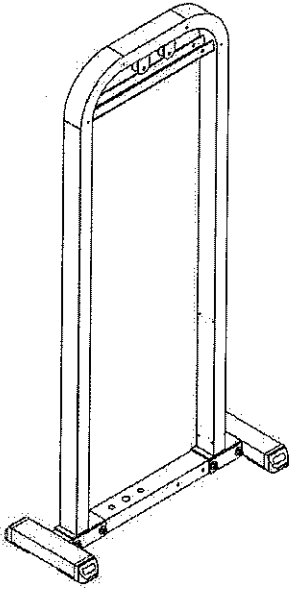

Above shows STEP 1 assembled and completed.

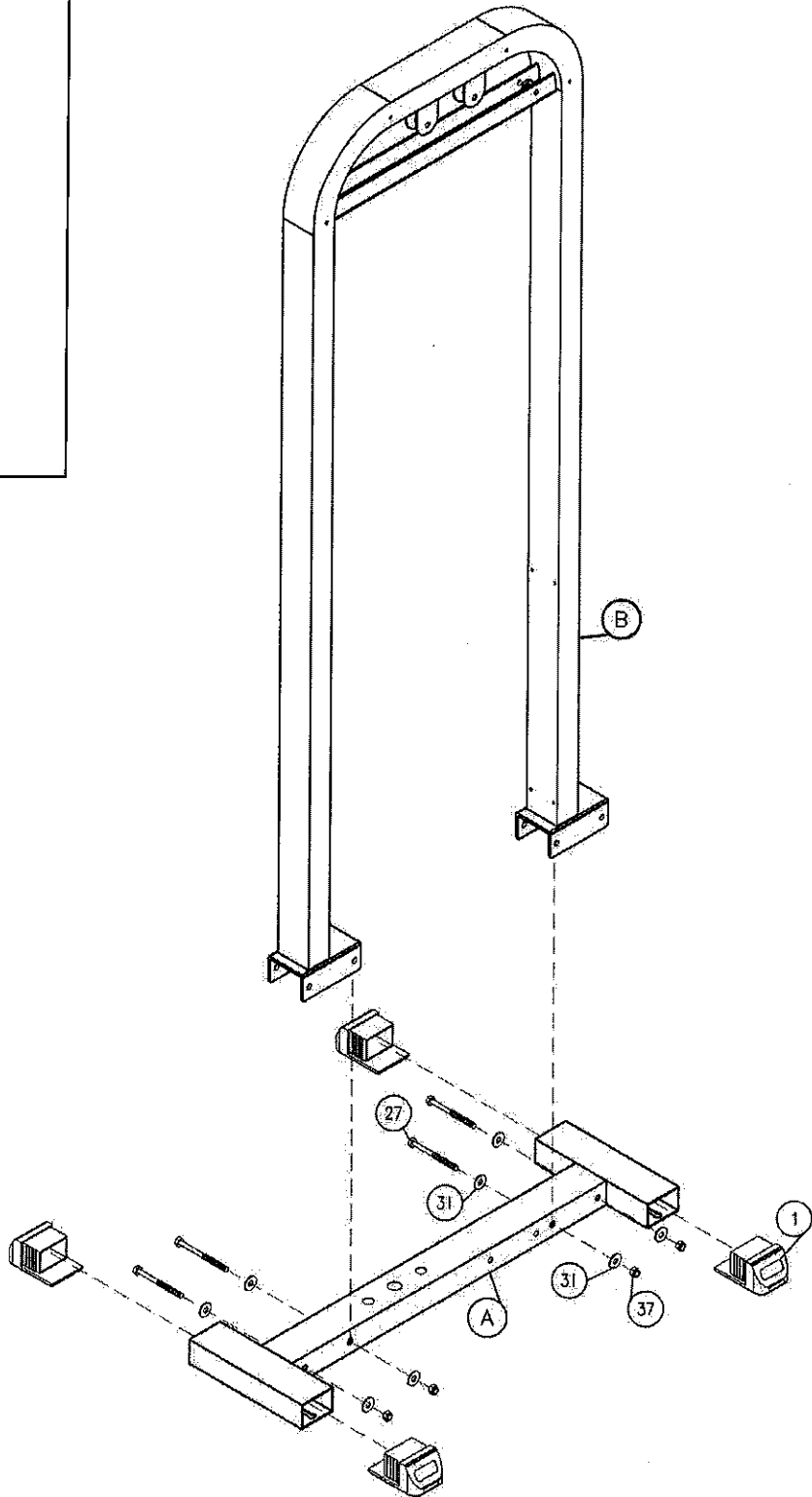

STEP

2

Be careful to assemble all components in the sequence they are presented.

- A. Install chrome guide rods (D) into the holes in the lower frame.
- B. Install weight raiser (15) and rubber donut (4) and slide to bottom of the guide rod.
- C. Tilt guide rods away from main frame and install weight plates (14). Be careful to hold guide rods steady when installing weight plates.
- D. Install chrome selector rod (12) into the top plate (13) and secure with allen head bolt (23) and washer (32) and fully tighten bolt. Install the spring lock washer (34) and jam nut (33) onto the selector rod top bolt (11) and install assembly into the top of the selector rod (12).
- E. Install top plate and selector rod assembly onto the guide rods.
- F. Install shaft collars (3) onto guide rods and align guide rods so they are directly below the guide rod holes in the upper section of the frame.
- G. Slide shaft collars upward, aligning the key extension on the shaft collars with the slot extensions in the upper frame holes.
- H. Turn shaft collars so they lock the guide rods into position and fully tighten allen screws (20).
- I. Install weight stack pin (6) and lanyard (5) assembly on the cable by installing cable through the key ring end.

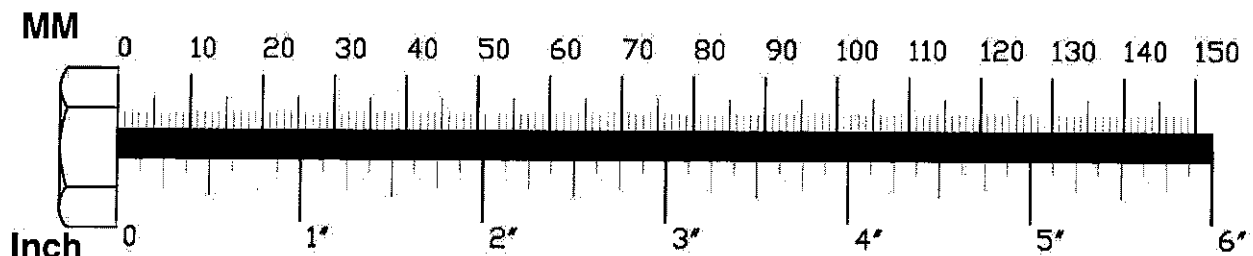

STEP
2

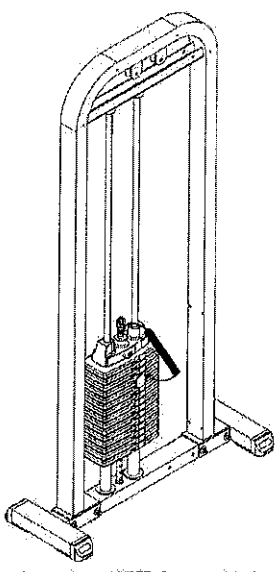

Above shows STEP 2 assembled and completed.

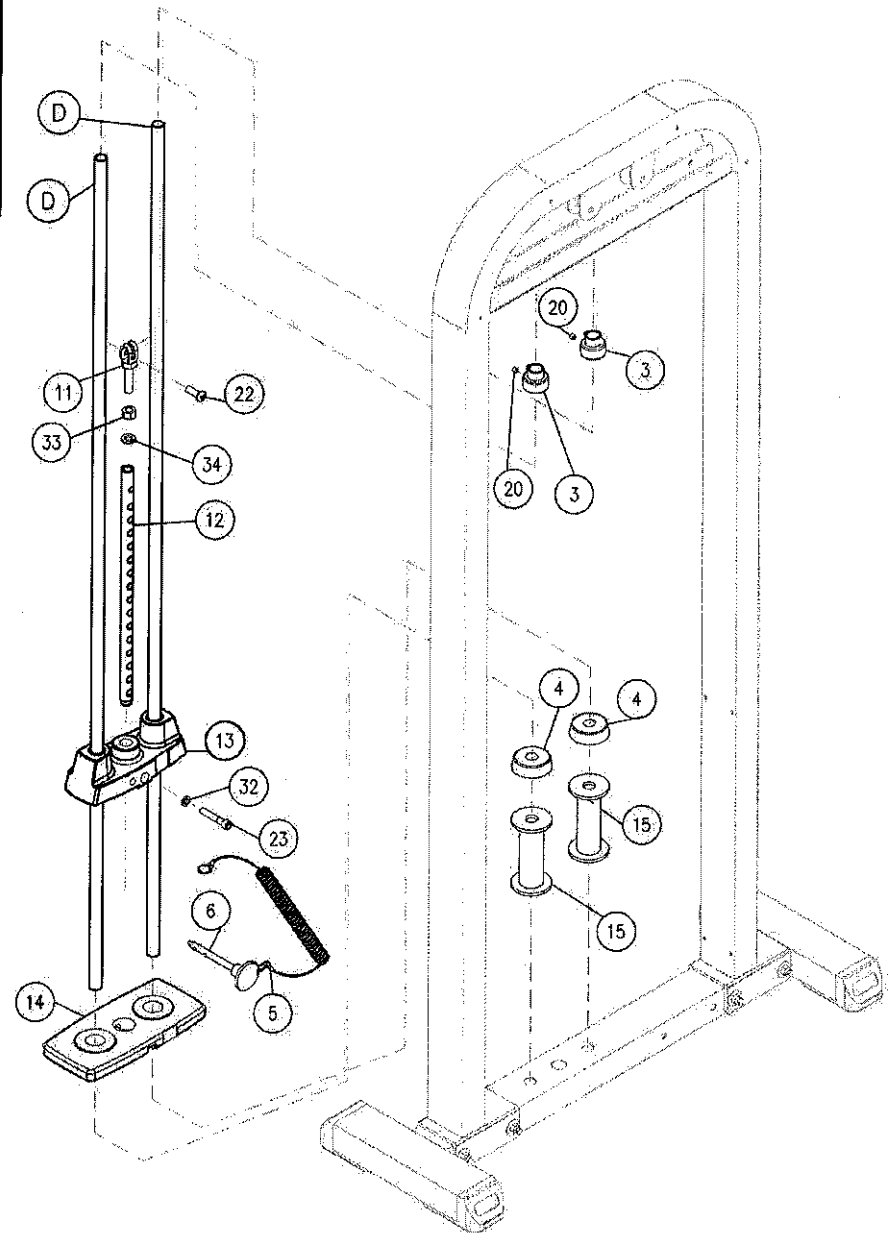

STEP

3

Be careful to assemble all components in the sequence they are presented.

- A. Install pulleys (2) into frame with bolt (25), washer (31), and nylon lock nut (37). Fully tighten bolts.
- B. Install cable end bolt (26) into frame with washers (31) and nylon lock nuts (37). Secure the lock bolt but do not fully tighten until after installing the cable.
- C. Assemble the floating pulley assembly by installing pulley (2) into pulley bracket (5) with bolt (25), washers (31) and nylon lock nut (37). Install chrome cap nut onto threaded end of pulley racket hook.

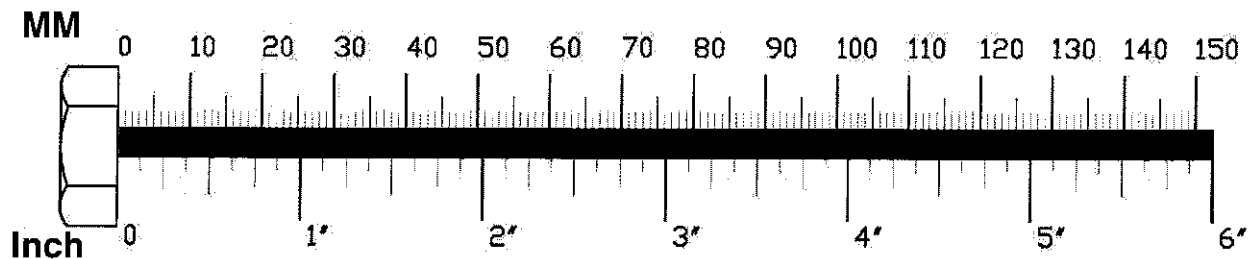

STEP
3

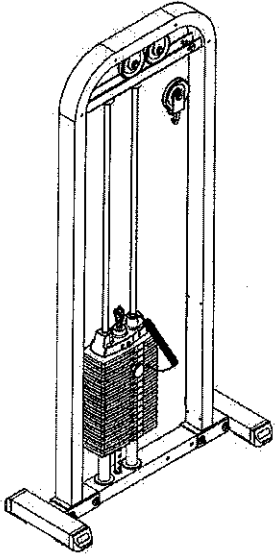

Above shows STEP 3 assembled and completed.

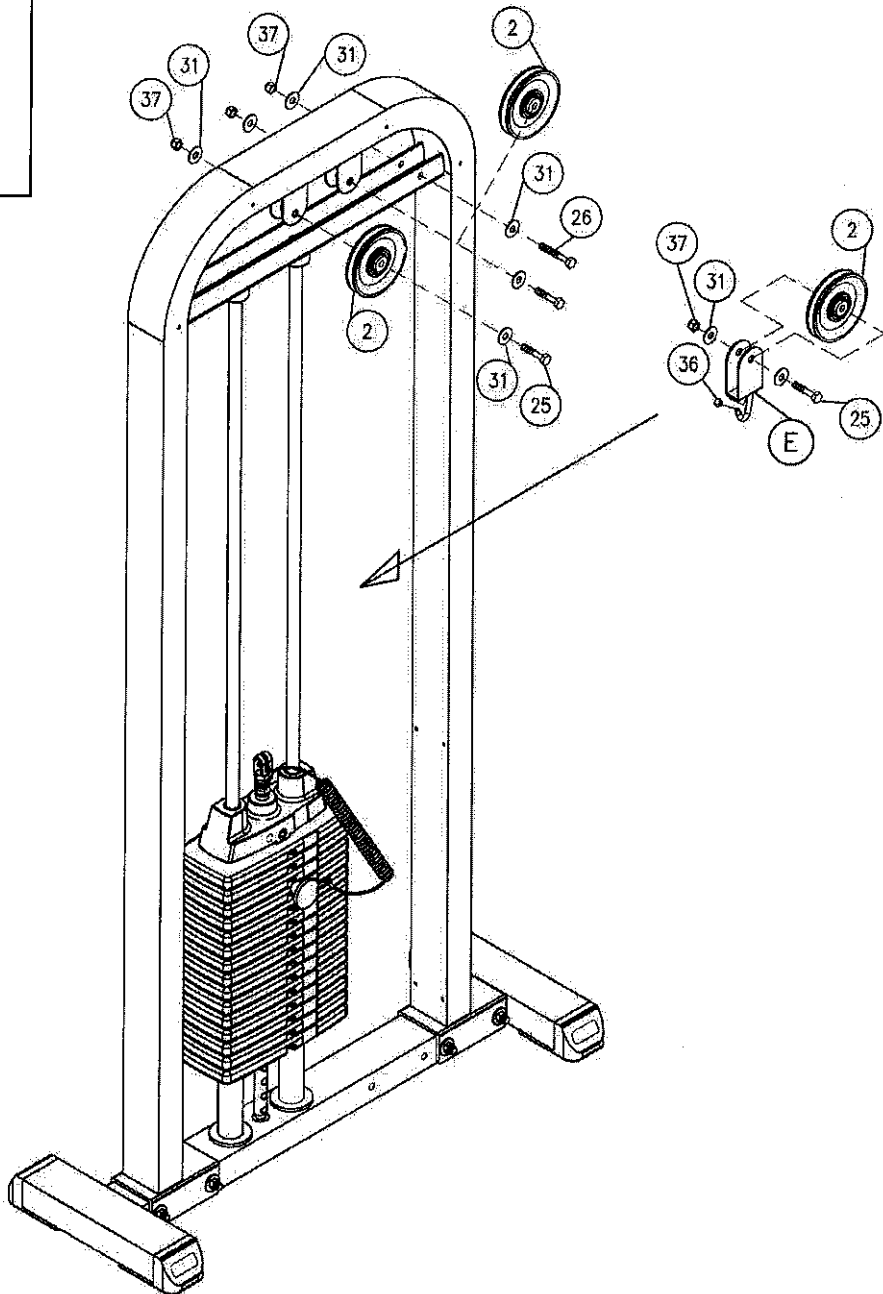

STEP**4**

Be careful to assemble all components in the sequence they are presented.

- A. Install cable by first assembling the ball end of the cable into the selector rod top bolt (11) and attaching the cable cylinder lock over the ball end. Secure with provided allen screw.
- B. Install cable over pulleys (A1 and A2) and through floating pulley assembly (A3).
- C. Attach cable end with open eye onto the bolt assembly (25). Fully tighten bolts.

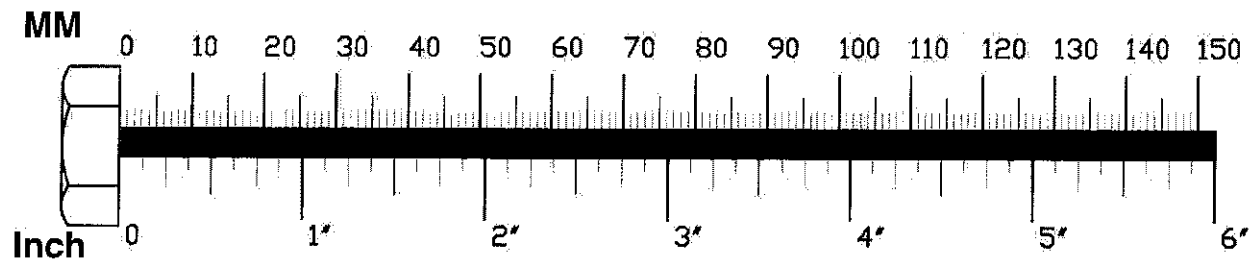

WARNING

Selector Rod Top Bolt (11) must be threaded a minimum of 1/2" into the Selector Rod (12), and Jam Nut (33) tightened securely against spring lock washer (34) to ensure proper connection. Check the Jam Nut (33) once a week to make sure it is tight.

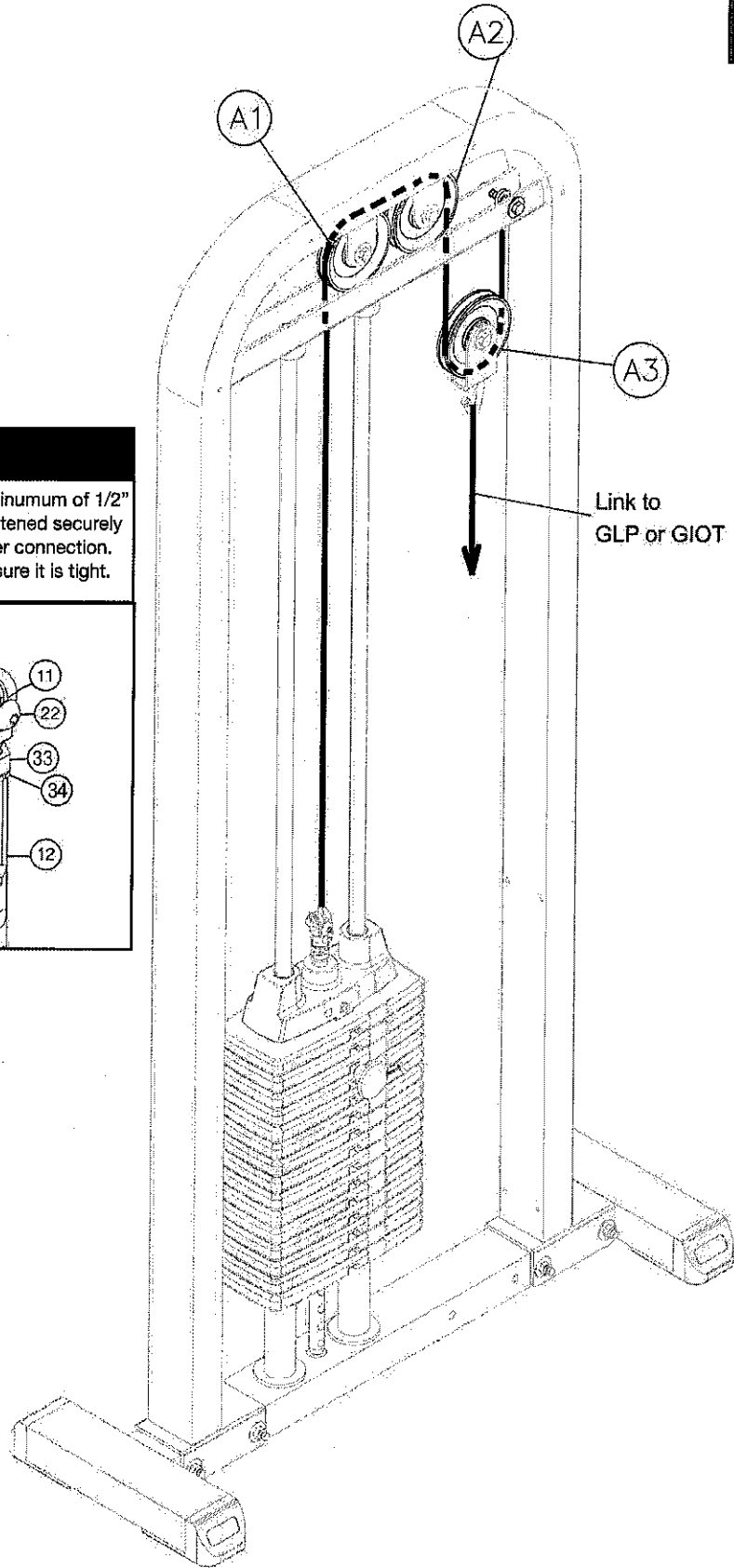
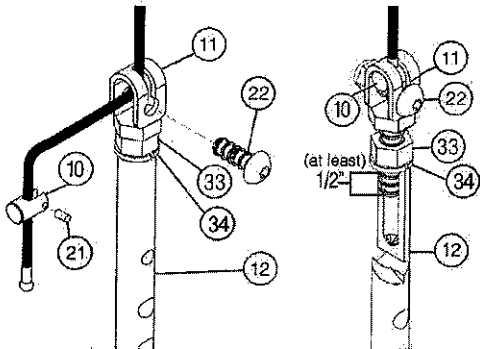

STEP**5**

Be careful to assemble all components in the sequence they are presented.

- A. Install pulley shrouds (C) onto frame with screws (24) and washers (30). Fully tighten screws.
- B. Attach completed assembly to Body Solid Inner / Outer Thigh or Leg Press machine.
- C. Bolts (E1), washers (E2), nylon nuts (E3), backing plate and extension link bar will be supplied with either of the exercise stations. The station can be installed on either side of the GSTCK assembly. Follow installation directions provided with the exercise station to attach to GSTCK.

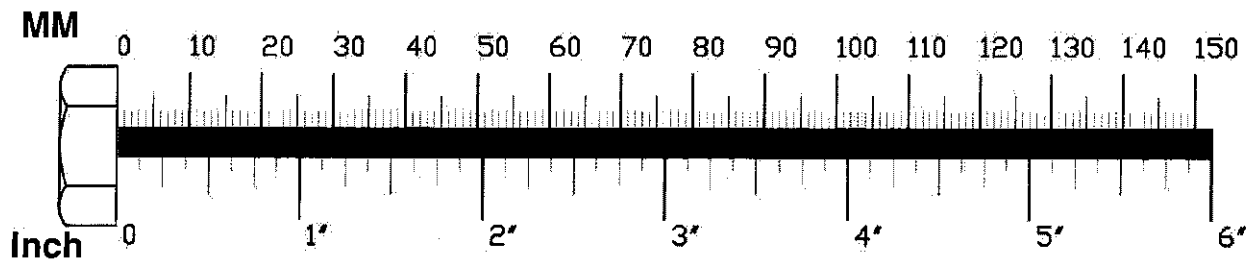

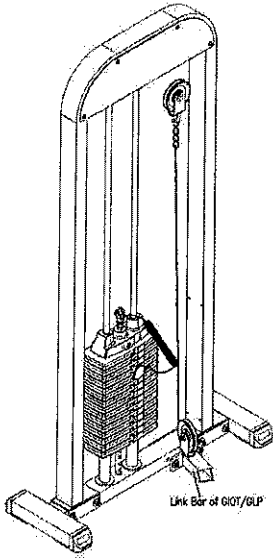

Above shows STEP 5 assembled and completed.

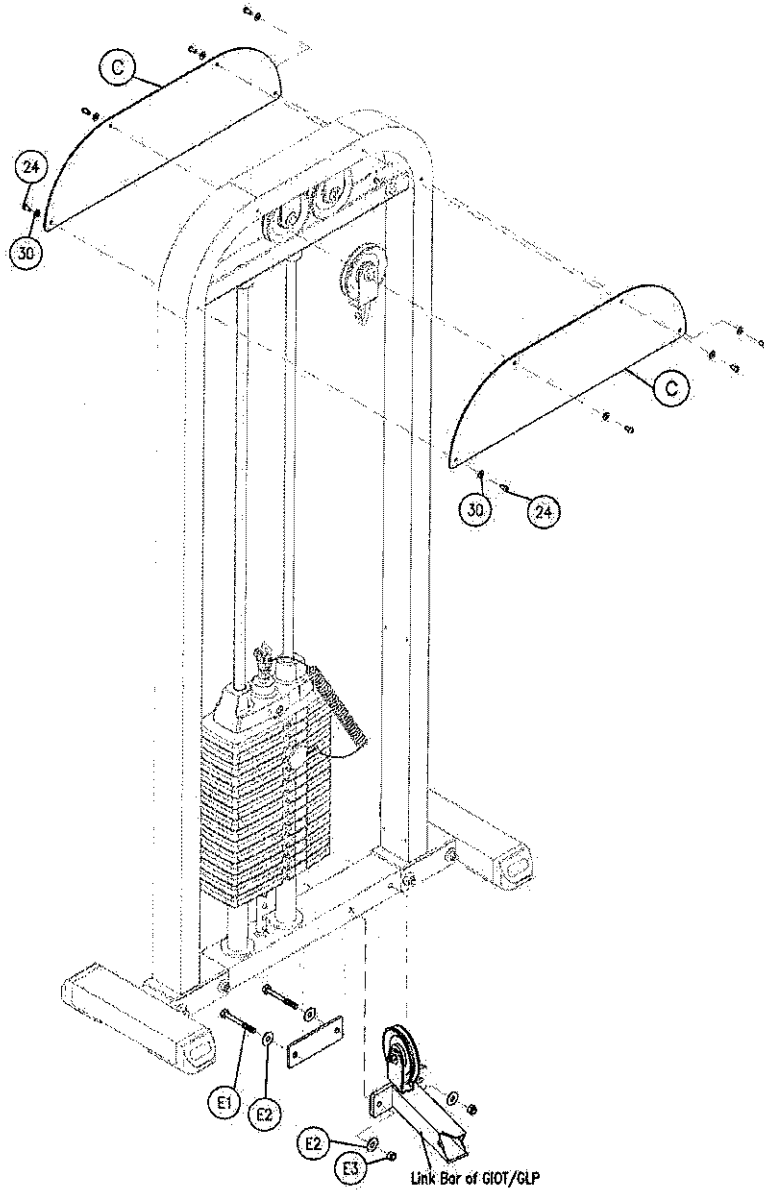

Note:
Hardware E1,E2,E3 are shipped with GLP/GIOT

G STACK Main Frame Parts List

KEY#	QTY	PART#	DESCRIPTION
A	1	STCKMF-A	LOWER MAIN FRAME
B	1	STCKUMF-B	UPPER MAIN FRAME
C	2	STCKSD-C	SHROUD
D	2	STCKGR-D	GUIDE ROD
E	1	STCKFPB-E	FLOATING PULLEY BRACKET

Key #, Part #, and Discription are required when ordering parts.

G STACK Hardware List

KEY#	QTY	PART#	DESCRIPTION
1	4	CFC23	FOOT CAP 2" X 3"
2	3	CPP4.25	PULLEY 4 1/4" OD
3	2	CSC	SHAFT COLLAR
4	2	CRD	RUBBER DONUT
5	1	CLAN	LANYARD
6	1	CWSP	WEIGHT STACK PIN
10	1	CCES	CABLE END SHAFT
11	1	CSRTB	SELECTOR ROD TOP BOLT
12	1	CSR	SELECTOR ROD
13	1	CTP10	TOP PLATE 10lbs
14	15/20	CWSP10	WEIGHT STACK PLATE 10lbs
15	2	CWR	WEIGHT RISER
20	2	CAS.31X.37FT	ALLEN SCREW 5/16" X 3/8" FULL THREAD
21	1	CAS.15X.37FT	ALLEN SCREW 5/32" X 3/8" FULL THREAD
22	1	CHEX.37X.87PTB	HEX HEAD BOLT 3/8" X 7/8" PARTIAL THREAD
23	1	CSHAB.37X2	SOCKET HEAD ALLEN BOLT 3/8" X 2"
24	8	CAS.25X.5	ALLEN SCREW 1/4" X 1/2" FULL THREAD
25	3	CHEX.37X2PTB	HEX HEAD BOLT 3/8" X 2" PARTIAL THREAD
26	1	CHEX.37X2.5PTB	HEX HEAD BOLT 3/8" X 2 1/2" PARTIAL THREAD
27	4	CHEX.37X4PTB	HEX HEAD BOLT 3/8" X 4" PRT THREAD
30	8	CWFLT.25	WASHER 1/4"
31	16	CWFLT.37	WASHER 3/8"
32	1	CSLW.37	SPRING LOCK WASHER 3/8"
33	1	CJN.5	JAM NUT 1/2"
34	1	CSLW.5	SPRING LOCK WASHER 1/2"
37	8	CNLN.37	NYLON LOCK NUT 3/8"

Key #, Part #, and Discription are required when ordering parts.