

Manual 891 E



Contents

Monark Exercise AB	4
Product Information	5
<i>Features.....</i>	5
<i>Serial number.....</i>	5
Operating Instruction.....	6
<i>Workload device</i>	6
<i>Power measurement.....</i>	6
<i>Cycle adjustments.....</i>	6
<i>Computer specifications.....</i>	7
<i>Adjustment brake cord tension</i>	8
Troubleshooting guide.....	9
Service.....	10
<i>Warning.....</i>	10
<i>Warranty</i>	10
<i>Service check & Maintenance.....</i>	10
<i>Batteries.....</i>	11
<i>Crank bearing</i>	11
<i>Flywheel bearing.....</i>	11
<i>Transport.....</i>	11
<i>Replacement of brake belt</i>	11
<i>Brake belt contact surface</i>	11
<i>Chain 1/2" x 1/8"</i>	12
<i>Freewheel sprocket.....</i>	13
Spare parts.....	14

Important

Read the manual carefully before using the cycle and save it for future use.

Monark Exercise AB

Monark has 100 years' experience of bicycle production. The Monark tradition has yielded know-how, experience, and a real feel for the product and quality. Since the early 1900s, Monark's cycles have been living proof of precision, reliability, strength and service. That are the reasons why we are now the world leader in cycle ergometers and the market leader in Scandinavia in transport cycles.

We manufacture, develop and market ergometers and exercise bikes, transport bikes and specialized bicycles. Our largest customer groups are within health care, sports medicine, public authorities, industry and postal services.

For more information: www.monarkexercise.se



Product Information

A stable arm ergometer that satisfies the requirements for fitness and endurance testing for the upper body. Monark's renowned weight basket system has been adapted for use in rehabilitation, development and following-up for people with physical disabilities. Ideal for exercise from a wheel chair.

NOTE!

Use of the product may involve considerable physical stress. It is therefore recommended people who are not accustomed to cardio or not feel completely healthy to first consult a physician for advice.

Features

- Adjustable stand for optimal position
- Control lever for releasing weight basket from sitting position
- Electronic display with heart rate
- Powder painted frame
- Wheels for easy transport

Width

700 mm (28")

Length

1500 mm (59")

Height

1660 mm (65")

Weight

60 kg (132 lbs) exclusive weights.
Delivered with 3,9 kg weights.

Included

Chestbelt

Serial number

The serial number of your Ergometer is placed according to *fig: Serial number*.

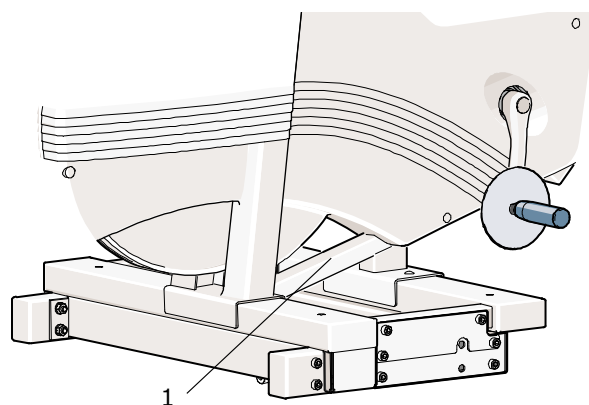

Fig: Serial number (1)

Operating Instruction

Workload device

Monark Ergomedic 891 E is a test device, applied with a braking system, where the brake force can be adjusted with weights on a weight carrier. Weights are available in 0,1 kg, 0,5 kg and 1,0 kg. Note: 0,1 kg is the minimum weight, which is the weight of the weight carrier. The weight carrier can also be placed in an upper level and then will no braking force be applied. Disengage the basket by pushing the knob(1). See *fig: Adjustments*.

Power measurement

The cycle is designed to measure the power on the flywheel, because tests/protocols are made for it (for example Åstrand's and YMCA).

Cycle adjustments

To adjust the height on the support stand pull the handle(2) outwards. Turn the handle clockwise to raise the stand and counterclockwise to lower it.

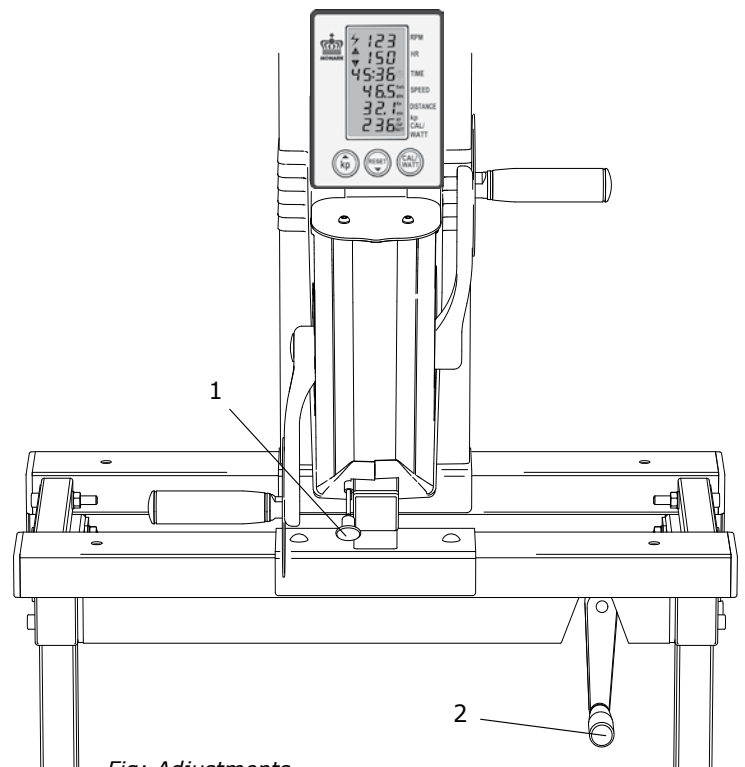
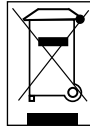

Fig: Adjustments
1) Disengagement knob
2) Handle, support stand

Computer specifications

Display		
RPM	0-250 (199)?	pedalrev./min
HR	50-240	bpm
TIME	0:00-99:59	min:sec
SPEED	0-99	km/h or mph
DISTANCE	0.0-99.9	km or mile
FORCE	0.0-7.0	kp
CALORIES	0-999	kcal
WATT	0.7 x RPM	watt

Batteries: 2 x 1.5 V, R6 (AA)
 Storing temperature: -10°C - +60°C
 Operating temperature: 0°C - +50°C



Press any button or move the pedal to turn on the computer.

At the display for heart rate (HR) a heart symbol is lit which means that the computer is trying to find a pulse signal from an external source (chestbelt with electrodes, Art. No: 9339-98).

If the computer can not find such a signal this HR function is automatically turned off after 30 seconds. When the function is turned off the heart symbol is not lit any more. The heart rate function can be turned on again by pressing a button.

Timer starts automatically when pedals are moved. Computer values for Time, Distance and Calories can be set to zero by pressing the RESET button for more than two seconds.

To receive the correct value for calories and watts the workload (kp) has to be set on the display. Kp value correspond to the total weight in the weight basket (weight of the basket, including the weights in it).

Example: The workload is 2,1 kg (weight basket 0,1 kg + 2 x 1kg weight). Press the kp button to the left on the display. Down in the display window figures is now flashing (kp). Increase or decrease in steps of 0.1 kp by pressing the kp button (arrow up) or the RESET button (arrow down) until the reading is corresponding with the actual or desired kp values (workload) from the weight basket. After that press the CAL/WATT button to either show the CAL or WATT figures.

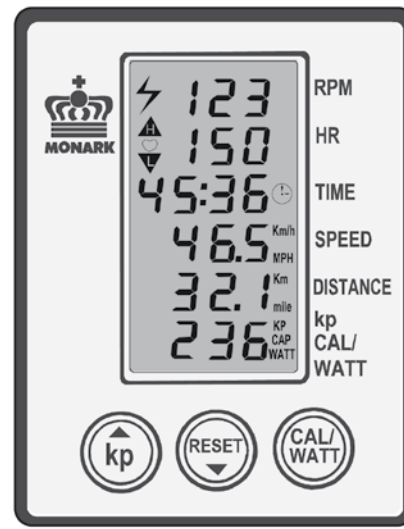

The watt reading in the display is depending on the pedalling speed. The watts can accordingly be adjusted by increasing or decreasing the pedalling speed. Calories are calculated all the time.

Setting KM or MILE

Km and km/h is the default setting from the factory. If you want to make settings in miles take the display out of the panel. Turn off the computer by taking out one battery.

On the back side is a switch with two settings - "1" and "ON". "1" is equal to km and km/h and is the default setting. "ON" is equal to mile and mph. Choose position and install the battery again. Put the display back again into the panel.

Do not expose the computer to direct sunlight or extremely high temperature. Do not use any dissolvents when cleaning. Use only dry cloth.

Adjustment brake cord tension

At first check that the brake cord is lying correct on the flywheel surface, see *fig: Brake cord*. Loosen the stop lever(2) from the tension center(1). Put 1 kg in the weight basket(4). Rotate the flywheel by hand. The basket shall now lift up so the distance to the flywheel is at least 40 mm, and maximum 60 mm. If it is not, the brake cord has to be loosened or tightened a little at the tension center. Lock the weight basket in its upper position with the stop(3) and after that loosen the lock washer(5) somewhat so that the cord length can be adjusted. If the basket is too low shorten the cord somewhat and if the basket is too high lengthen the cord somewhat. Tighten the lock washer again, release and check if the measurement above is OK when the flywheel is rotated by hand.

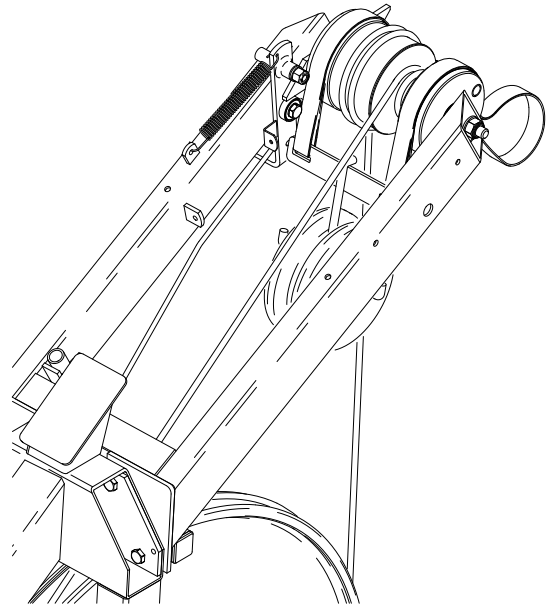

NOTE!

To receive correct workload it is important to place the weight basket according to the description above. If the basket hangs too low it may touch the flywheel. If the basket is too high, wrong workload may obtain.

Fig: Brake cord
1) Tension center
2) Stop lever
3) Stop
4) Weight basket (0,1kg)
5) Lock washer

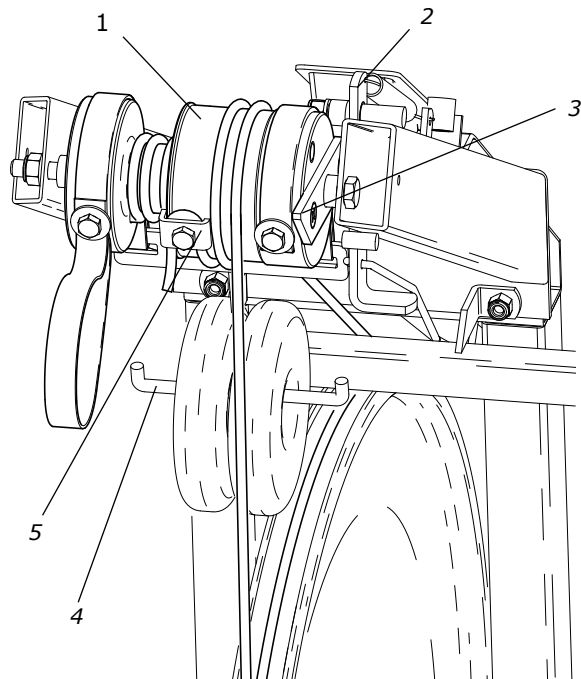

Troubleshooting guide

Symptoms	Probable Cause/Corrective Action
The weight basket moves up and down.	The brake belt contact surface may need to be ground off. See description in section "Brake belt contact surface".
The weight basket touch the flywheel.	The brake cord is probably not enough tightened. The basket can be loaded with a lot of weight. Tighten the brake cord according to section "Adjustment brake cord tension".
According to test the bike seems to give too high workload.	The brake cord may be too tighten. Loosen the cord according to section "Adjustment brake cord tension".
There is a click noise with every pedalling (increases with the weight).	The pedals are not tightly drawn, tighten them or change pedals. There is a loose in the crank cheek, tighten. There is a loos in the base bearing, contact your dealer for service.
Scratching sound is heard when pedalling.	Check that the carriage block is taken off and that none of the covers is scratching.
There is a click noise and a squeak noise when pedalling.	Untighten the chain a bit.

Service

Warning

Make sure the voltage indicated on the appliance corresponds to the local mains voltage before making connections.

Warranty

EU countries - Private use

If you are a natural person you will have a minimum level of protection against defects in accordance with EC Directive 1999/44/EC. In short, the directive provides for that your Monark Dealer will be liable for any defects, which existed at the time of delivery. In case of defects, you will be entitled to have the defect remedied within a reasonable time, free of charge, by repair or replacement.

EU countries - Professional use

Monark Exercise products and parts are guaranteed against defects in materials and workmanship for a period of one year from the initial date of purchase of the unit. In the event of a defect in material or workmanship during that period above, Monark Exercise will repair or replace (at its option) the product. Monark Exercise will do so at its expense for the cost of materials but not for labour or shipping.

Other countries

Monark Exercise products and parts are guaranteed against defects in materials and workmanship for a period of one year from the initial date of purchase of the unit. In the event of a defect in material or workmanship during that period above, Monark Exercise will repair or replace (at its option) the product. Monark Exercise will do so at its expense for the cost of materials but not for labour or shipping.

Service check & Maintenance

To keep your Ergometer in good shape you should make a regular service.

Service action:

- If you wish to disinfect the surface of the bike we recommend isopropyl alcohol. Use a damp but not wet cloth to clean the surface you wish to disinfect.
- Keep your Ergometer clean and properly lubricated (once a week).
- Periodically wipe the surface with a rust preventative, especially when it has been cleaned and the surface is dry. This is done to protect the chrome- and zinc parts as well as the painted parts (4 times per year).
- Check now and then that both pedals are firmly tightened. If not the threading in the pedal arms will be damaged. Also check that pedal arms are firmly tightened on the crank axle, tighten if necessary. When the Ergometer is new it is important to tighten the pedals after 5 hours of pedalling (4 times per year).
- Check that the pedal crank is secure to the crank axle (4 times per year).
- Be sure that the pedals are moving smoothly, and that pedal axle is clear of dirt and fibres (4 times per year).
- When cleaning and lubricating be sure to check that all screws and nuts are properly tightened (2 times per year).
- Check that the chain is snug and there is no play in the pedal crank (2 times per year).
- Check that pedals, chain and freewheel sprocket are lubricated (2 times per year).
- Be sure that the brake belt does not show significant signs of wear (2 times per year).
- Check that the handlebars and seat adjustment screws are lubricated (2 times per year).
- Be sure that all moving parts as crank and flywheel are working normal and that no abnormal play or sound exists. I.e. play in bearings causes fast wearing and with that follows a highly reduced lifetime.
- Check that the flywheel is placed in the center and with plane rotation.

Batteries

If the meter is battery-operated, the batteries are in a separate package at delivery. If the storing time has been long the battery power can be too low to make the computer act correctly. Batteries must be changed.

Crank bearing

The crank bearing is long term greased and require normally no supplementary lubrication. If problem arises, please contact your Monark dealer.

Flywheel bearing

The bearings in the flywheel are lifetime greased and require normally no maintenance. If problem arises, please contact your Monark dealer.

Transport

At transport the brake belt should be somewhat tightened to prevent it from falling off the flywheel.

Replacement of brake belt

To replace the brake belt remove covers if necessary. Make sure that the belt is loose.

Alt. 1: To loosen the belt on pendulum bikes with motor, turn the power on and move the pendulum to 4 kp. Hold it there until brake belt is loose. Observe how the belt is connected. Take it apart and remove it from the bike. Attach the new brake belt and assemble the bike in reverse order.

Alt. 2: To loosen the brake cord on cycles with weight basket set the basket to its upper position. Loosen the lock washer that is holding the cord and remove it from the tension center. Loosen or cut of the knot in the other end of the cord and then remove the hole cord from the bike. When assembling a new brake cord, first enter one end into the hole in the tension center, and tie a knot and let the knot fall into the bigger part of the hole. Lock the end of the cord with the lock washer.

Alt. 3: To loosen the belt on other bikes remove all possible tension. Observe how the belt is connected. Take it apart and remove it from the bike. Attach the new brake belt and assemble the bike in reverse order.

NOTE: When replacing the brake belt it is recommended to clean the brake surface. See "Brake belt contact surface".

Brake belt contact surface

Deposits of dirt on the brake belt and on the contact surface may cause the unit to operate unevenly and will also wear down the brake belt. The brake belt contact of the flywheel surface should then be ground off with fine sandpaper and any dust removed with a clean dry cloth.

Remove if there are any covers and loosen the tension on the brake belt. Grind with a fine sandpaper. Grinding is easier to perform if a second individual cautiously and carefully pedals the cycle.

Irregularities on the brake belt contact surface are removed by means of a fine sandpaper or an abrasive cloth. Otherwise unnecessary wear on the brake belt may occur and the unit can become noisy.

Always keep the brake belt contact surface clean and dry. No lubricant should be used. We recommend replacing the brake belt when cleaning the contact surface. In regard to assembly and adjustment of the brake belt, see "Replacement of brake belt".

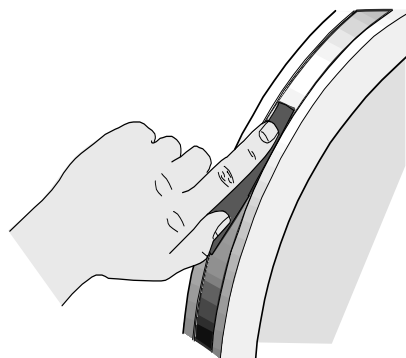

Chain 1/2" x 1/8"

It is strongly recommended to keep the chain clean. Dirt build-up on the chain will cause excess wear. A chain lubricant and solvent for normal road bikes may be used.

Check the lubrication and tension of the chain in regular intervals. In the middle of its free length the chain should have a minimum play(3) of 10 mm (1/4 inch). See *fig: Chain adjustments*. When the play in the chain is about 20 mm (3/4 inch) it must be tightened otherwise it will cause abnormal wear of the chain and chainwheels. Because of this it is always recommended to keep the chain play as little as possible. Loosen the hub nut(2) on both sides and tense the chain with the chain adjuster(1) when needed.

When the chain has become so long that it can no longer be tightened with the chain adjusters it is worn out and shall be replaced with a new one.

To adjust or replace the chain remove frame covers if necessary.

To adjust the chain the hub nuts(2) should be loosened. Loosening or tightening the nuts on the chain adjusters(1) will then move the hub and axle forward or backward. Adjust according to above recommendation. Then tighten the nuts on the hub axle again. See *fig: Chain adjustments*.

To replace the chain loosen the chain adjuster as much as possible. Dismantle the chain lock(6) and remove the chain. Put on a new chain and assemble the chain lock. The spring of the chain lock should be assembled with the closed end in the movement direction(5) of the chain. Use a pair of tongs for dismantling and assembling the spring(4). See *fig: Chain replacement*.

NOTE: At assembly the flywheel has to be parallel with the centerline of the frame otherwise the chain and chain wheels makes a lot of noise and wears out rapidly.

Adjust chain adjusters to allow chain play according to above. Tighten hub nuts firmly. Put on frame covers again.

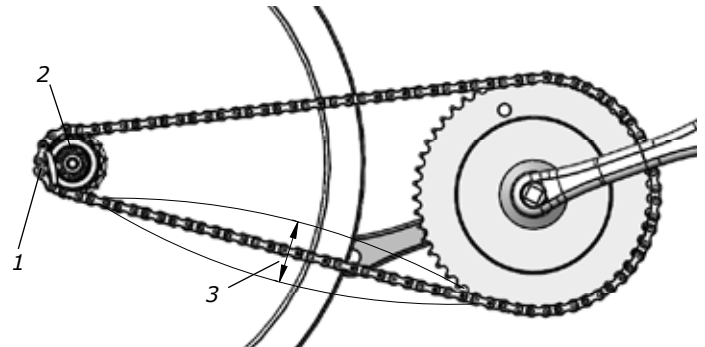

Fig: Chain adjustments
1) Chain adjuster
2) Hub nut
3) Chain play

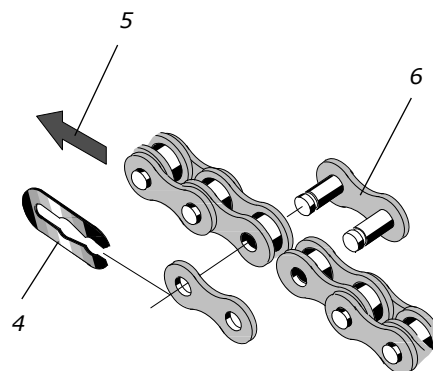

Fig: Chain replacement
4) Lock spring
5) Movement direction
6) Chain lock

Freewheel sprocket

When replacing the freewheel sprocket remove frame covers if necessary. Dismantle the chain as described in part "Chain 1/2" x 1/8" ".

Loosen the axle nuts and lift off the flywheel. Remove the axle nut, washer, chain adjuster and spacer on the freewheel side. Place the special remover (Art. No: 9100-14) in the adapter and place the spacer and axle nut outside. See *fig: Special remover*. Replace sprocket-adapter and assemble the new parts in reverse order according to the above.

NOTE: Do not tighten the axle nut completely. It must be possible to loosen the adapter-sprocket half a turn.

The sprocket should be lubricated with a few drops of oil once a year. Tilt the cycle somewhat to make it easier for the oil to reach the ball bearing. See *fig: Lubrication*.



Fig: Lubrication



Fig: Special remover
(Art. No: 9100-14)

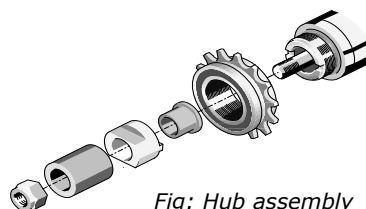
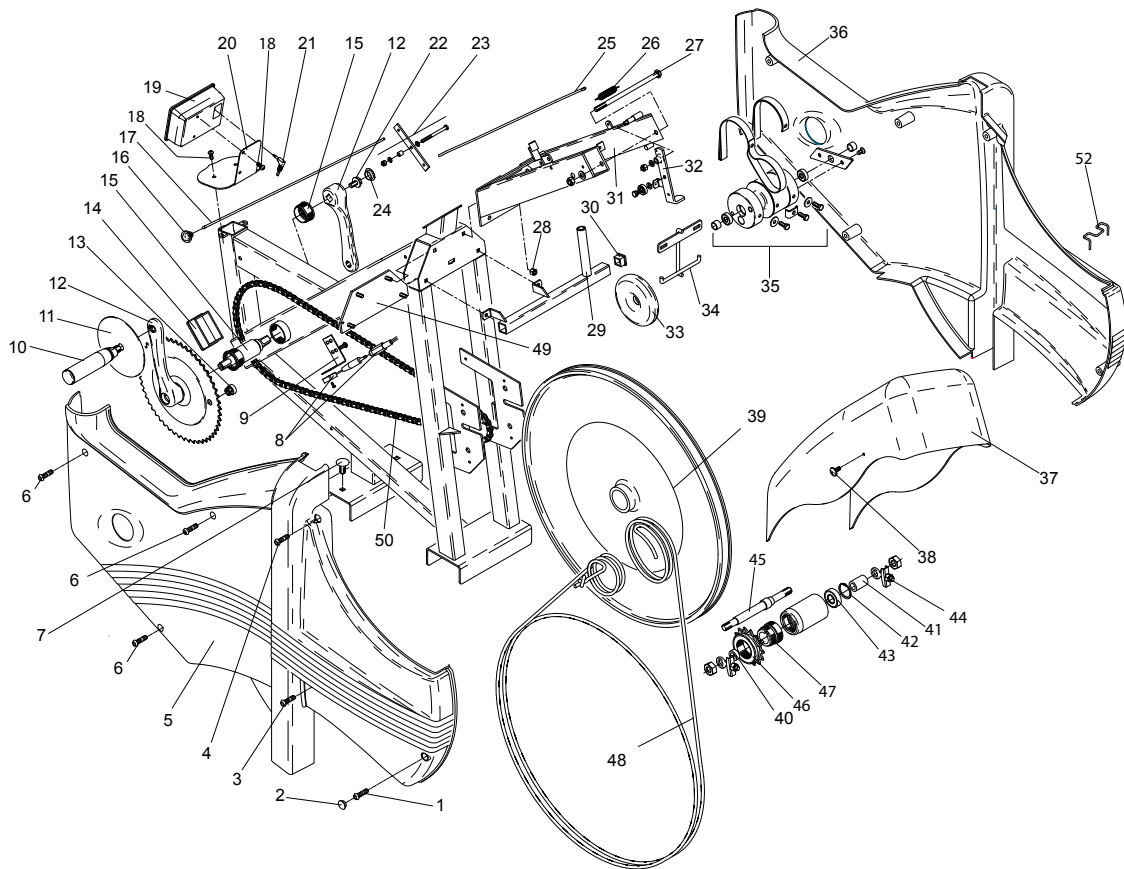
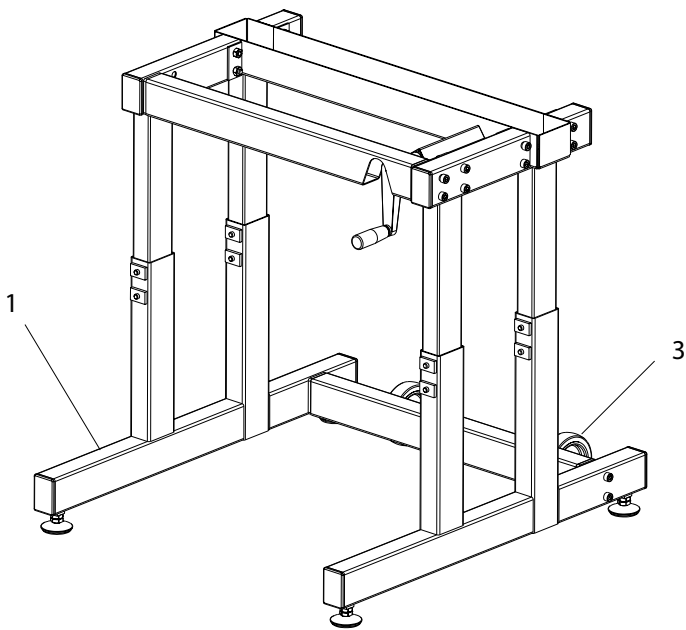
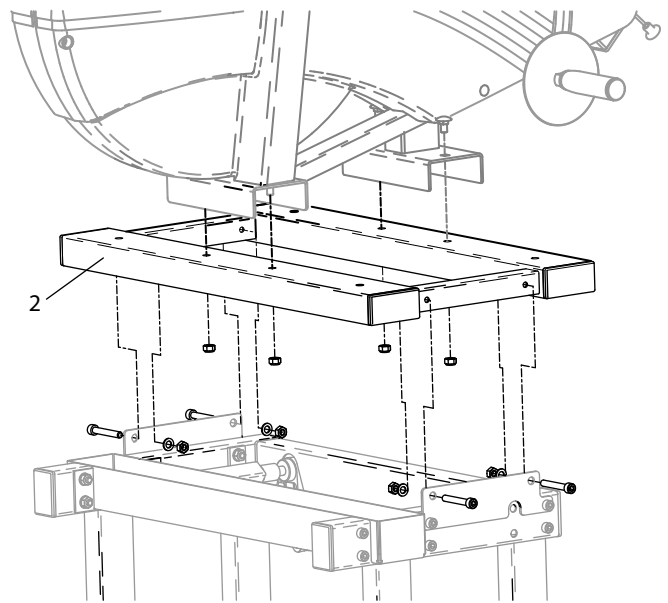

Fig: Hub assembly

Spare parts



Pos.	Qty.	Art. No.	Description	Pos.	Qty.	Art. No.	Description
1	1	5683	Screw	27	1	14374	Screw
2	10	9306-12	Plastic plug	28	4	5843-9	Nut
3	2	5673-9	Screw	29	1	9374-29	Weight holder
4	1	5681	Screw	30	2	9302-28	Plastic plug
5	1	9391-62	Frame cover, right	31	1	9374-9	Front frame
6	3	5671-19	Screw	32	1	9374-150	Stop lever, complete
7	2	9300-12	Screw	33	1	9391-400	Weight set, complete
8	1	9326-162	Crank sensor with cable	34	1	9391-25	Weight basket 0,1 kg
9	1	9326-166	Sensor holder	35	1	9374-20	Tension device, complete
10	1	9145-71	Handle, pair	36	1	9391-61	Frame cover, left
11	2	9371-71	Handcover	37	1	9391-141	Instrument cover
12	1	9300-450	Crank set, complete	38	2	5675-9	Screw
13	1	9326-164	Magnet	39	1	9391-3	Flywheel with sprocket
14	1	9391-55	Plastic cap	40	1	9000-17	-Spacer 5 mm
15	1	8966-175	BB cartridge bearing, complete	41	1	9300-17	-Spacer 23 mm
16	1	9391-44	Knob	42	1	9000-15	-Locking ring SgH 028
17	1	9391-40	Push rod	43	2	19001-6	-Ball bearing SKF 6001-2z
18	4	5673-9	Screw	44	1	9000-12	-Chain adjuster, pair
19	1	9391-70	Digital meter	45	1	9300-18	-Axle, length 132 mm
20	1	9391-26	Meter holder	46	1	9106-13	-Sprocket, 14t
21	1	9326-263	Cable	47	1	9106-14	-Connection for above
22	2	8523-115	Screw	48	1	9324-30	Brake belt
23	1	9391-43	Link, complete	49	1	9374-60	Bracket
24	2	8523-2	Dust cover	50	1	9300-5	Chain 116 L, with chain lock
25	1	9391-41	Push rod	51	1	9384-45	Control
26	1	9100-20	Spring		1	9339-98	Chestbelt



Pos.	Qty.	Art. No.	Description	Pos.	Qty.	Art. No.	Description
1	1	9391-80	Table stand, complete, height-adjustable				
2	1	9391-9	Upper part				
3	2	9000-29	Transport wheel, complete				
	1	9391-8-10	Screw set				



Version 1010
Art. No: 7950-310

